

# Wi-Fi Based Smart Energy Meter

Koastubh Chaturvedi<sup>1</sup>, Ravi Gupta<sup>2</sup>

<sup>1,2</sup>Dept. of Electrical and Electronics Engineering., PSIT Kanpur, UP, India

**Abstract-** Home automation is fast popularity nowadays. An automatic remote meter-reading system based on Wi-Fi is presented in this paper can be considered as a part of home automation. The Energy data collection system is a very important step and part in the research of energy visualization and analysis. Through this system, consumer can easily know their electricity usage at any instance and their behavior to reduce their energy consumption and costs. Wi-Fi based smart energy meter system is presented in this paper is in terms of reduces errors, absence of consumer while taking reading etc. There are many possibilities to collection of energy data. The main aim of the paper is to develop remote energy measurement system using Raspberry pi board consisting ARM11 processor and use sensors. Sensors data are stored in Raspberry pi and sends related data over Wi-Fi through the home's wireless router to the base station. Furthermore, display all data such as energy consumption (Power), unit or other sensors detail on LCD. The base station collects the energy data, stores it in database and uses it for energy visualization, calculation and analysis using GUI application on Qt Creator. The design of GUI for embedded systems is different from that of traditional data computing, which often handles mouse or keyboard events to complete a specific calculation, while for embedded systems the events are caused by external devices.

**Index Terms-** Base Station, LCD, Qt Creator, Raspberry Pi, Sensors, Wi-Fi Module.

## I. INTRODUCTION

The present billing systems have many problems like problem of payment collection, energy thefts, quality of photographs that is printed on bill etc. due to which the traditional billing system is slow, costly and unreliable. The present billing system has chances of error and it is also time consuming. Also, in the existing meter system, consumers are presented with usage information only once a month with their bill.

A smart energy meter is typically electronic equipment that stored consumption data of energy in

intervals of an hour, minute or less and communicates that information at any time for monitoring and billing purposes. Smart energy meter is electronics device that communication between the base station and the energy meter. A Base station is based on an application which extracts the data from TCP/IP protocol, sent by the energy measurement unit. The entire communication system is based on TCP/IP protocol which is a standard implemented by almost all the systems. It provides a static link between measurement unit and base station based on IP addresses.

This paper introduces a new kind of energy data collection system which is using Raspberry Pi, Wi-Fi module and Sensors. In this way of design, the work can be done in any situation no matter what kind of electricity meter it is. The rest of the paper is structured as this. The Second chapter will show the idea of proposed system. The hardware and software will be design in the third chapter. This chapter explains about the architecture and interfacing of the components being used. Forth chapter is experimental results and output of the system and fifth chapter is design and creates GUI application for smart meter. Conclusions and benefits are summarized in sixth chapter. Finally, the acknowledgement and reference is stated in the last part.

## II. PROPOSED METERING SYSTEM ARCHITECTURE

The proposed system is divided into two parts such as Energy measurement unit and base station with embedded Qt Creator. Fig. 1 shows an overview of the proposed metering system.

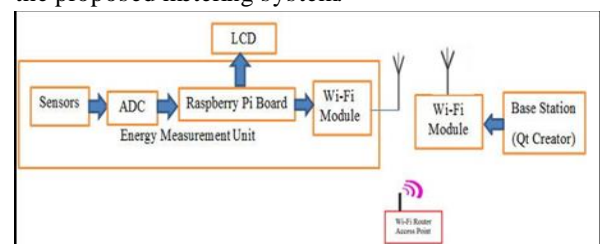

Figure 1: Overview of Proposed metering system  
 The sensor module contains various sensors such as current sensor, voltage sensor and temperature sensor. These sensors are automatically measure the current, voltage and temperature. These sensors are connected to raspberry pi via ADC. The ADC is connected to the Raspberry Pi at the SPI pin. The sensors data will be sending to the SPI pin that will be taken as an input of the raspberry pi and is sent to the base station. The raspberry pi collects these sensor's data for the energy calculation, visualization and analysis.

The raspberry pi equipped with LCD to display power consumption and other related information .The Wi-Fi module is responsible to send energy data to the base station and base station responsible to insert these data to the database in particular consumer number. These data is then accessed by using GUI application .The temperature is used only for high alerts. If the temperature goes to high then system will cut off the large-scale power device and the alarm will ring to notify the consumer. We can also extend wireless Wi-Fi network between energy meter unit and base station using wireless repeater.

III.DESIGN & IMPLEMENTATION

This system can be design and implement by two parts:

A. Hardware Design

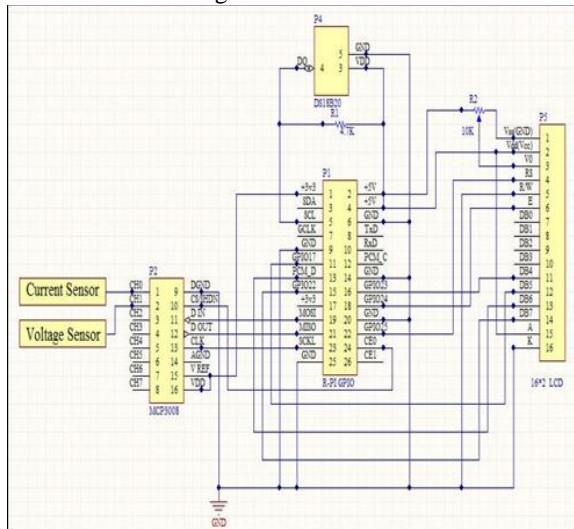

Figure2: Schematic of the smart energy meter  
 The raspberry pi is a credit sized, low cost and single board computer, it is advanced by raspberry pi foundation in the UK. It is controlled by Raspbian

Linux OS optimised for the ARM architecture. It has five models model A, model A+, model B, model B+ and latest model Generation 2 model B.The Model B+ has 512 MB RAM, Broadcom BCM2385 ARM11, 700 MHz low power System on chip CPU. Dual core Video core IV GPU and 4 USB 2.0 ports with up to 1.2A Output. The various sensors are connected to the ADC and it is connected to the raspberry pi. The raspberry pi does not has built in analog input and sensors will have an analog output, so it can be converted into digital using analog to digital converter (ADC). The ADC uses the SPI bus protocol which is configure by the raspberry Pi's GPIO header. The ADC used here is MCP3008.It is a 10bit 8-channel Analogue-to-digital converter. It is cheap, easy to connect and does not require any additional hardware.

The Voltage, Current and Temperature are measured using Hall Effect current transformer, voltage transformer and temperature sensor DS18B20. These sensors are continuous measure current and voltage and result of measurement is saved in a text file at regular time interval.

B. Software Design

The software side of this system is divided into programmed running on raspberry pi (Raspbian OS) and GUI running on base station and SQLite database. In this paper user interface is designed in Qt Creator. It is popular Graphical User Interface that used in embedded Linux as well as Windows. Qt Creator is free and open source software. All editions support many compilers and debuggers, including the Visual Studio suite and the GCC C++ compiler. Qt is a cross-platform application framework that is widely used for developing application software with a GUI and used for developing non-GUI programs such as command-line tools and consoles for servers.

Qt for Embedded Linux is a C++ framework for graphical user interface and application development for embedded devices. Qt for Embedded Linux provides the standard Qt Application program interface (API) for embedded devices with a lightweight Graphics system. Qt is a cross-platform application and UI framework for writing web-enabled applications for mobile, desktop and embedded operating systems.

Some mouse events in GUI are used to calculate energy related data from sensors and stored in database. These data are taken from various energy meter and accessed particular meter data from GUI application. This is also used to show consumption and billing information of consumer in graphical format.

IV.IMPLEMENTATION RESULTS

```
File Edit View Search Terminal Help
pi@raspberrypi: ~/Documents/RaspberryPi-mcp3008Spi-master $ ./Outbin
The Result is: 513
The Result is: 513
The Result is: 512
The Result is: 512
The Result is: 512
The Result is: 512
The Result is: 514
The Result is: 514
The Result is: 514
The Result is: 512
The Result is: 512
The Result is: 512
The Result is: 513
The Result is: 512
The Result is: 512
The Result is: 513
The Result is: 513
sum 10252
Average=512
Value=2.49856
The Current =0.9856
pi@raspberrypi: ~/Documents/RaspberryPi-mcp3008Spi-master $
```

Figure 3: Output of CT Sensor

```
File Edit Tabs Help
pi@raspberrypi: ~/RaspberryPi-mcp3008Spi-master
pi@raspberrypi: ~/RaspberryPi-mcp3008Spi-master $ g++ -Wall -o Outbin mcp3008Spi.cpp mcp3008SpiTest.cpp
The Result is: 1023
The Result is: 1023
The Result is: 1023
The Result is: 1023
The Result is: 1023
The Result is: 1023
The Result is: 1023
The Result is: 1023
The Result is: 1023
The Result is: 1023
The Result is: 1023
The Result is: 1023
The Result is: 1023
The Result is: 1023
The Result is: 1023
The Result is: 1023
The Result is: 1023
The Result is: 1023
The Result is: 1023
The Voltage is: -2.49347
pi@raspberrypi: ~/RaspberryPi-mcp3008Spi-master $ import -window root 5.png
```

Figure 4: Output of Voltage sensor

```
Activities GNOME Terminal Wed 23:47
pi@raspberrypi: ~/Desktop
File Edit View Search Terminal Help
pi@raspberrypi: ~/Desktop $ sudo modprobe v4l2loopback
pi@raspberrypi: ~/Desktop $ sudo modprobe v4l2loopback
pi@raspberrypi: ~/Desktop $ cd /sys/bus/v4l/devices/
pi@raspberrypi: /sys/bus/v4l/devices $ ls
28-00005940ee9 v4l_bus_master1
pi@raspberrypi: /sys/bus/v4l/devices $ cd 28-00005940ee9
pi@raspberrypi: /sys/bus/v4l/devices/28-00005940ee9 $ ls
driver id name power subsystem v4l_slave
pi@raspberrypi: /sys/bus/v4l/devices/28-00005940ee9 $ cat v4l_slave
99 01 40 46 7f 0d 10 02 : crc=92 VES
99 01 40 46 7f 0d 10 02 : t=20187
pi@raspberrypi: /sys/bus/v4l/devices/28-00005940ee9 $ cd
pi@raspberrypi: ~ $ cd Desktop/
pi@raspberrypi: ~/Desktop $ ls
i.c epiphany-browser.desktop p1store.desktop simple_gv_img.8
Build your own cross compilation tool chain in Linux.pdf iife.desktop jny sonic-pi.desktop
client_server_example_program iife8.desktop python-games.desktop temp.c
Linux iif.py scratch.desktop temp.py
New.c liteminal.desktop shutdown.desktop v4lfron-language.desktop
RaspberryPi: mcp3008Spi-master mincraft-p1.desktop simple_gv_img v4lfron-mathematisra.desktop
debian-reference-common.desktop ocr_resources.desktop simple_gv_img wpa_gui.desktop
pi@raspberrypi: ~/Desktop $ python temp.py
25.197
pi@raspberrypi: ~/Desktop $
```

5: Output of Temperature sensor



Figure 6: Database of billing system

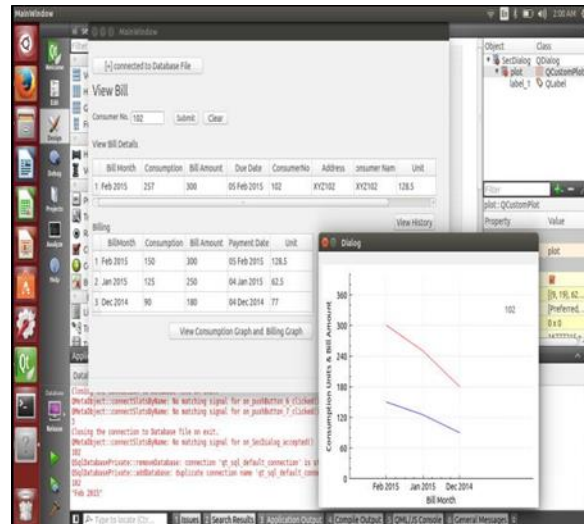

Figure 7: Complete GUI application for smart energy meter

V.CONCLUSIONS

The embedded technology is develops fast and the design of GUI application is important and essential mechanisms of it. This paper will make ease of reading and reduce error in reading and reporting. It

develops a measurement system and GUI application based on Qt Creator/Embedded that will graphically shows the measured data. Furthermore, it will improve metering, billing efficiency and accuracy, thereby contributing the energy in a maintainable way. Also, it will eliminate manual meter reading system, monitoring the electric system more rapidly, making it possible to use energy resources more efficiently and providing real-time data useful for balancing electric equipment or loads and reducing energy outages. Through this system, users can easily understand their electricity usage at any instance. Here data transmitted over wirelessly, so there is not any issue of electromagnetic interface.

#### ACKNOWLEDGMENT

In engineering one of the best ways of studying is, while doing project, since it helps the practical knowledge of the subject, which can be achieved successfully by putting efforts in making it successful with co-operation of teacher. I would like to express our best regards to my project guide Mr. Amol Borole whose valuable guidance, encouragement, and provision of necessary facilities made this work possible.

#### REFERENCES

[1] Chunchi Gu, Hao Zhang, Qijun Chen College of Electronics and Information, Tongji University, Shanghai, P.R.China,” Design and Implementation of Energy Data Collection System Using Wireless Fidelity (Wi-Fi) Module and Current Transformer”,2014 IEEE International Conference on System Science and Engineering (JCSSE) July 11-13 2014, Shanghai, China

[2] A. Ali ,N.A. Razali ,N. Vitee ,N.H. Saad ,” Implementation of Automatic Meter Reading (AMR) Using Radio Frequency (RF) Module”,2012 IEEE International Conference on Power and Energy(PECon),2-5 December 2012,Kota Kina balu Sabah, Malasiya Claudio De Capua, Gianluca Lipari, Mariacarla Lugarà, Rosario Morello” A Smart Energy Meter for Power Grids” Instrumentation and Measurement Technology Conference (I2MTC)

[3] Proceedings, 2014 IEEE International 12-15 May 2014

[4] Unnati Patel, Vijay N. Chavda “ Real Time Monitoring System based on Embedded Linux Application”,2014 IJEDR | Volume 2, Issue 2 | ISSN: 2321-9939

[5] Fang Hongping, Fang KangLing, “The Design of Remote Embedded Monitoring System based on Internet” International Conference on Measuring Technology and Mechatronics Automation,, 2010.

[6] Internet:<http://www.raspberrypi.org/help/>[October 15,2014]

[7] <http://hertaville.com/2013/07/24/interfacing-an-spi-adc-mcp3008-chip-to-the-raspberry-pi-using-c/>

[8] Vujovic, V. Maksimovic, M.,”Raspberry Pi as a Wireless Sensor Node: Performances and Constraints “,MIPRO 2014, 26-30 May 2014, Opatija, Croatia

[9] Primicanta, A H. ,Nayan, M. Y., &Awan, M. (2010, June). ZigBee-GSM based automatic meter reading system. In Intelligent and Adranced Systems (ICIAS), 2010 International Conference on (pp. 1-5). IEEE.

[10] Itir Christian D. Bongamay, JosefC. Magno, Adrian G. Marcellana, John Marvin E. Morante, Noel G. Perez,” Automated Electric Meter Reading and Monitoring System using ZigBee-Integrated Raspberry Pi Single Board Computer via Modbus” ,Electrical, Electronics and Computer Science ,2014 IEEE Students Conference 1-2 March 2014