

# Analysis of Electrified Application of Transformer Less Hybrid Series Active Filter

Monika<sup>1</sup>, Dr.R.Arulmurugan<sup>2</sup>

*PG Scholar, Dept. of Electrical and Electronics Engineering, SR Engineering College, Warangal*  
*Associate Professor, Dept. of Electrical and Electronics Engineering, SR Engineering College, Warangal*

**Abstract-** This paper presents a transformer less hybrid series active filter (THSeAF) that enhance the power quality in single-phase systems with constant supply that supports critical loads and behaving as high-harmonic impedance that does not below the critical loads, it cleans power system and ensures the use of unity power factor. Here we deals with energy management and power quality issues related to electric transportation and focus on improving the electric vehicle load connected to grid. This is based on the Power Factor Correction (PFC) conversion with harmonic modulation technique that will give betterment of power factor in PFC operation. The control strategy was designed to prevention of current harmonic distortions with the nonlinear loads to control the flow of utility without any usual bulky and costly transformer. Power factor along with AC side will also maintained to some value and also eliminate the voltage distortions at the Common coupling point. Here we protecting sensitive loads from voltage distortions, swells and sags with respect to power system, without the series transformer it is advantageous for an industrial implementation. This paper carried out with 2-kVA power demonstrating the effectiveness of the existing topology.

**Index Terms-** Power factor correction, Dynamic voltage restore, Transformer less hybrid series active filter, Series active filter, Source current harmonics, Voltage distortion, power quality improvement.

## I. INTRODUCTION

The forecast of future smart grid associated with electric vehicles charging stations leads to serious concerns for power quality in power distribution system. The harmonics generated by non-linear loads (electric vehicle batteries) indeed have a great impact on the system which effects the equipment should be considered in modern grid. The increased current distorts heat, losses and causes failure of equipment.

This phenomenon must be eliminated, which reduces the efficiency of the system [1].

To prevent voltage distortion at the point of common coupling PCC, Dynamic Voltage Restorer is advised. Another way to protect the system is to directly reduce the pollution of power electronics based loads at their source. There are other attempts to protect the plant. There exist two active devices to overcome described power quality issues [2]. The first category is series active filter Series Active Filter (SeAF) including hybrid, can reduce current harmonics fed from non-linear loads. Shunt active filters are well known compared to series active filters. But there is a great advantage of series active filters that is low level compensators can be used. Howe ever, the complex configuration and necessity of isolation of series transformer makes in an industrial application [3]. The second category is to compensate voltage issues. A Dynamic Voltage Restore (DVR) is same as SeAF. These two categories are different from each other in control principles. The difference depends on the purpose of the system.

The advantage of the proposed system is it can compensate the harmonic voltage and currents produced by non-linear loads [4]. Transformer less Hybrid Series Active Filter is an alternate option to the conventional power transferring converts, where each phase can be controlled and operated without disturbing other phases [5]. This paper demonstrates that the separation of three phase converter to a single phase H-bridge converter has allowed the elimination of transformer cost by isolating transformer and encourages industrial application for filtering purposes. The setup has shown great effectiveness in the requested performance in solving the problems of current and voltage distortions, power factor PF on load terminals. The overall block diagram as shown in Fig.1

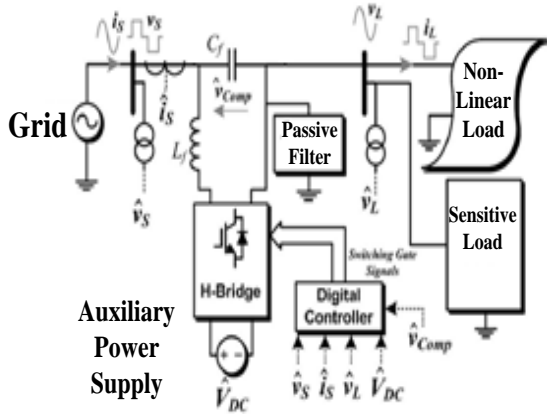

Fig.1 Proposed Electrical diagram of the THSeAF in a single phase utility

harmonics [6]. A DC auxiliary source is connected to inject voltage during voltage sags. This grid is developed for a 2.2 KVA rated power. The proposed system parameters are shown in a Table.1 and Table.2. A source of 120Vrms is connected to 1.1KVA nonlinear load, 998VA linear load and 0.46PF [7]. The THSeAF is connected in series to inject the voltage during the time of distortion. On DC side the compensator (H-bridge) auxiliary source is connected. HSeAF is mostly used for Compensating distortions in current type of non-

Symbol	$v_s$	$F$	$L_f$	$C_f$	$G$	$V_{DCref}$	$PI_G$
Definition	Line phase-to-neutral voltage	System frequency	Switching ripple filter inductance	Switching ripple filter capacitance	Control gain for current harmonics	VSI DC bus voltage of the THSeAF	Proportional gain ( $K_p$ ), integral gain ( $K$ )
Value	120 Vrms	60 Hz	5 mH	2 $\mu$ H	8 $\Omega$	70 V	0.025(4*) 10(10*)

Table.1.Load Side Configuration parameter

Symbol	$R_{non-linear load}$	$L_{non-linear load}$	$P_L$	$PF$	$T_s$	$f_{PWM}$	$PI_G$
Definition	Load resistance	Load inductance	Linear load power	Linear load power factor	dSPACE Synchronous sampling time	PWM frequency	Proportional gain ( $K_p$ ), integral gain ( $K$ )
Value	11.5 $\Omega$	20 mH	1 KVA	46%	40 $\mu$ H	5 kHz	0.025(4*) 10(10*)

## II. PROPOSED THSeAF

The Transformer less Hybrid Series Active Filter (THSeAF) consists of an H-bridge converter connected in series between source and load. A shunt passive filter provides a low impedance for current

linear loads. For example the distorted voltage and current harmonics are shown in Fig.2 during regular operation and when distortion is occurred due to non-linear loads.

This proposed configuration can directly connect to the grid with isolating the bulky transformer makes the topology capable of controlling current harmonics, voltage distortion at the point of common coupling PCC [8]. Even if the number of switches are increased in the system. This THSeAF very effective and less costly compared to any series compensators, which have to connect the transformer to inject voltage into the power grid to compensate voltage distortion [9]. The passive filters consist of high pass filters [10]. A comparison between existing system and the proposed system is given in Table.3 . The advantages of proposed topology over existing are clearly stated.

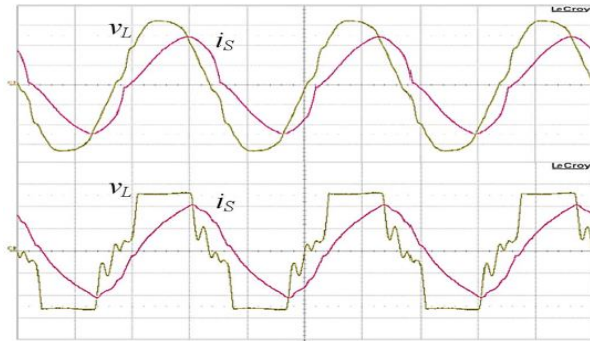

Fig. 2. Regular operation and grid's voltage distortion [1]

To understand the comparison table an equivalent single phase of each configuration as shown in Table.3. Estimation of production in financial is 45% reduction in components cost and also reduction in assembly terms.

Table.3. Single phase comparison of the THSeAF to existing SeAF [2]

Definition	Proposed THSeAF			
	non	2 per phase	1 per phase	1 per phase
Injection transformer	non	2 per phase	1 per phase	1 per phase
# of Semiconductor devices	4	8	4	4

# of DC link storage elements	1+Aux. Pow.	1	2	1+Aux. Pow.
AF rating to the load power	10-30%	10-30%	10-30%	10-30%
Size and weight regarding the transformer, power switching drive circuit, heat sinks, etc.	The lowest	High	Good	Good
Industrial production costs	The lowest	High	Low	Low
Power losses including switching, conducting and fixed losses	Low	Better	Low	Low
Reliability regarding independent operation capability	Good	Low	Good	Good
Harmonic correction of current source load	Good	Good	Good	Low
Voltage Harmonic correction at	Good	Better	Good	Good

load terminal				
Power factor correction	Yes	Yes	Yes	No
Power injection to the grid	Yes	No	No	Yes

*A. Equivalent circuit configuration for current harmonics*

The THSeAF acts as a VSI. To prevent the source from current harmonics which drift from the non-linear load, SeAF should provide low impedance for fundamental components and high impedance for all harmonics as indicated in Fig.3

The passive filter is mandatory to compensate current issues and voltage distortion and to maintain balanced voltages at load terminal. The performance of a SeAF for a current control is considered from Fig.3 of phasor equivalent circuit. The non-linear load is nothing but a resistance representing active power consumed and generated harmonic current impedance represent nonlinear load. If source current is free from harmonics that will improve the voltage distortion at the grid. The THSeAF acts as low impedance for harmonics and passive filters acts as low impedance for all harmonics and open circuit for fundamental. This also improves power factor.

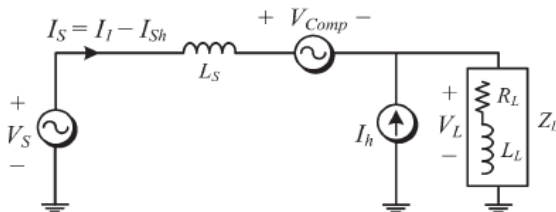

Fig.3 THSeAF equivalent circuit for current harmonics [1]

*B. Control schemes of THSeAF and Proportional Integral*

A DC auxiliary is connected to get a balanced supply at the load terminals. During the time of sags and swell DC auxiliary is used to inject or absorb power to keep the voltage magnitude at a particular limit at

the load terminal. But still, if the compensation of voltage sag and swell is less imperative, a capacitor can be installed. Then, the DC link voltage across the capacitor will regulate as shown in Fig.4

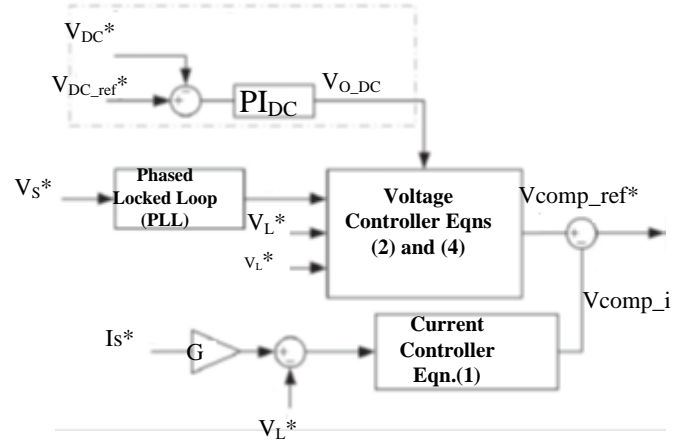

Fig.4 control system scheme of the active part [3]

An outer loop controller is used where a capacitor can replace an DC auxiliary source. An inner loop control strategy is indirect control principle. Gain represents as the impedance for current harmonics in a suitable level to clean the grid from harmonics which are fed from non-linear loads.

The second Proportional Integral (PI) controller in the outer loop is to enhance the effectiveness when regulating the DC bus. Thus, more accurate and faster response will be achieved without compromising the compensation performance of the system. The gain should be kept in such a way that the current harmonics are prevented from flowing into the grid. As discussed for more accurate compensation of current harmonics, the voltage harmonics must be taken into consideration. The compensation of voltage is done to compensate the current harmonics is shown in Fig.5

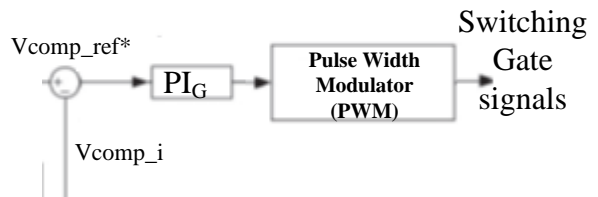

Fig.5 block diagram of THSeAF and PL controller

The voltage distortions are not desired at the load terminals, the voltage sags and swell are investigated in the inner loop. The closed loop equations help us

to indirectly maintain voltage magnitude at load side must be equal to ( $V_L$ ) within a specified limit.

The complete control scheme of the proposed system THSeAF is shown in Fig.6 is implemented in MATLAB/ Simulink for real time simulations and calculation of the compensating voltage, the source voltage and load voltage along with the source current is given as the input signal to the system indirect control increases the stability of the system. The difference between the source current and fundamental components gives the source current harmonics.

Where  $V_{dc}$  reference is the voltage required to maintain the dc bus voltage constant. A phase locked loop PLL is used to get the reference angular frequency. The current harmonics contain fundamental components are similar to the source voltage in order to correct the power factor. This currents represents the reactive power of the load. Gain acts as resistance to the harmonics and converts current into a reactive voltage. The voltage which is generated from the loop will clean the source current from harmonics. After that, a reference signal is compared with the measured output voltage and applied to the PI controller to generate gate signals.

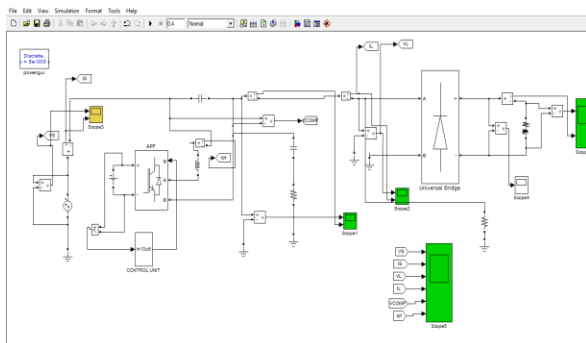

Fig.6. Proposed overall simulation setup of proposed THSeAF system

### III. PROPOSED RESULTS AND DISCUSSIONS

The proposed transformer less HSeAF is simulated in MATLAB as shown in Fig.6. A single phase non-linear load with a rated power of 2KVA with 0.74 lag power factor is applied to Simulation [9]. A 2KVA, 123Vrms 60Hz variable source is used [10]. The THSeAF connected in series to the system to compensate the current harmonics and voltage distortions.

A gain  $G=8$  ohms equivalent 1.9P.U by referring is to control current harmonics. The capability to operate the system with low DC voltage is the main advantage of the proposed system[14].

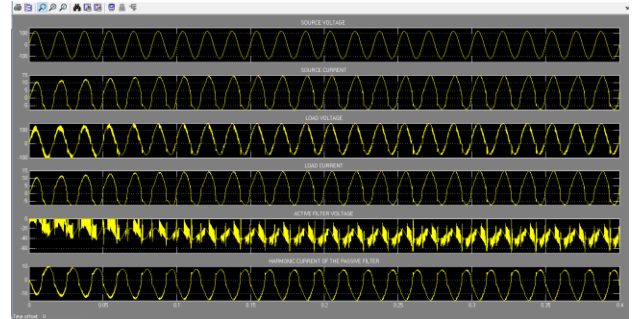

Fig.7 waveforms of THSeAF in set up diagram a) voltage source b) current source c) load voltage d) load current e) active filter voltage compressor f) harmonic current passive filter.

DC auxiliary is given as 130Vdc. During voltage distortion the compensator controls the current harmonics, voltage magnitude at load and corrects power factor [11]. The simulated results of THSeAF are shown in Fig.7 which shows the improvement of source current [12].

The grid is now balanced with protecting the system from current harmonics with a unity power factor operation [13]. Since the series controlled source prevents current harmonics, the source current is forced to be in phase with source voltage.

The series compensator has the capability to regulate the load voltage so that the power factor becomes unity. The series compensator is used to control the power flow between two point of common coupling's PCC [14].

### IV. CONCLUSION

The purpose of this proposed system is to improve the power quality of the system by compensating harmonic currents and to improve and regulate the PCC voltage. By connecting the auxiliary source it can counteract the power flow in the system for constant power supply, when critical loads are connected. The configuration was simulated and validated. This active compensator provides constant and distortion free supply to the load terminals and also it eliminates the source harmonic current and improves power quality of the grid by isolating the transformer.

## REFERENCES

- [1] C. Emmott, B. Azzopardi, N. Espinosa, R. Garcia-Valverde, A. Urbina, J. Mutale, F. C. Krebs, and J. Nelson, "Economical assessment of solar electricity from organic photovoltaic systems," in *Renewable Power Generation (RPG 2011), IET Conference on. IET*, 2011, pp. 1–2.
- [2] D. Sixing, L. Jinjun, and L. Jiliang, "Hybrid Cascaded H-Bridge Converted For Harmonic Current Compensation", *IEEE Trans Power Electronics*, vol.28, No.5, pp.2170-2179, 2013.
- [3] Alireza Javadi, Kamal Al-Haddad, "A Single-Phase Active Device for Power quality improvement of electrified Transportation", *IEEE Transactions on Industrial Electronics*, vol.62, no.5, pp.3033-3040, 2015.
- [4] A.Kuperman, U. Levy, J. Goren, A. Zafransky, and A. Savernin, "Battery Charger For electric vehicle tranction battery switch station", *IEEE Trans. Power electronics*, vol.60, no.12, pp.5391-5399, 2013.
- [5] H. Akagi And K. Isozaki, "A Hybrid Active Filter For A three-phase 12-pluse diode rectifier used as the front end of a medium – voltage motor drive", *IEEE Trans. Power electronics*, vol.27,no.1,pp.69-77, 2007.
- [6] Arulmurugan, R, "Comparative evaluation of new FLC controller based MPPT for a DC to DC buck-boost zeta converter" *WSEAS Transactions on power systems*, vol.11, pp.27-34, 2016
- [7] R. Scung-Hee, K. Dong-Hee, K. Min-Jung, K. Jong-Soo, And L. Byoung-Kuk, "Adjustable Frequency Duty-Cycle Hybrid Control Strategy For Full-Bridge Series Resonant Convertors In Electric Vehicle Chargers", *IEEE Trans. Industrial Electron*, vol.61, no.10, pp.5354-5362, 2014.
- [8] R.Arulmurugan and Dr.N.Suthanthiravanitha, " Model and design of fuzzy-based Hopfield NN tracking controller for standalone PV applications", *Elsevier -International Journal of Electric Power Systems Research (IJEPEs)*, vol.120, pp.184-193, 2015. DOI 10.1016/j.epsr.2014.05.007
- [9] Arulmurugan, R and Venkatesan, T, 'Research and Experimental Implementation of a CV-FOINC Algorithm Using MPPT for PV Power System', *Journal of Electrical Engineering and Technology*, vol.10, no.1, pp. 30-40, 2015
- [10] Arulmurugan, R and Dr.Venkatesan T 2015, 'Performance calculation and probability lifecycle price investigation of standalone photovoltaic power supply for a residential applications', *Proceeding of Online International Conference on Green Engineering and Technologies at Karpagam College of Engineering, Coimbatore, India*, pp.1-6
- [11] H. Abu-Rub, M. Malinosky, and K.Alhadad, "Power Electronics For Renewable Energy Systems, Transportations, Industrial Applications", Chichester, U.K..Wiley InScience, 2014.
- [12] J. Liu, S. Dai, Q. Chen, And K. Tao, "Modelling And Industrial Application of Series Hybrid Active Power Filter", *IET Power Electron*, vol.6, no.8, pp.1707-1714, 2013.
- [13] H.Liqui, X.Jian, O.Hui, Z.Pengju, and Z.Kai, "High-performance indirect current control sceme for railway traction four-quadrant convertors", *IEEE Trans. Industrial Electronics*, vol.61, no.12, pp.6645-6654, 2014.
- [14] R.Arulmurugan et al, "Adaptive fuzzy logic control based optimal Hopfield neural network of standalone photovoltaic system with battery storage", *Journal of Renewable and Sustainable Energy (JRSE), AIP*, Vol.6, pp.033113-19, May 2014. DOI: 10.1063/1.4878844