

LOW COST WIRELESS HEALTH MONITORING SYSTEM

P.Sowmya¹, Banu priya.N²

¹PG scholar , M.E Embedded Systems Technologies

²Assistant Professor, Department of ECE

Sri Ramakrishna Engineering College, Coimbatore, India

Abstract— A low-cost, portable, wireless health monitoring is proposed in this paper. Patient's electrocardiogram (ECG), body temperature and heart rate information are acquired and sent to a doctor using ARM9 processor through GSM. Technology based on the level of Emergency a video on first aid procedures is sent from the doctor to the patient/caregivers which is displayed on the Graphical LCD Display. Further a pulse oximeter and changes in blood volume can be measured. Win CE which is a Linux based platform and Qt Creator is a cross-platform C++, JavaScript and QML integrated development environment which is part of the SDK for the Qt GUI Application development framework. It includes a visual debugger and an integrated GUI layout. Qt Creator uses the C++ compiler from the GNU Compiler Collection on Linux and FreeBSD.

Index Terms— ARM9 ,GSM, WinCE, Qt creator,GUI, Healthcare monitoring, ECG.

I. INTRODUCTION

Recently, the health care sensors are playing a vital role in hospitals. The sensors used are inexpensive and are easy to use by the caregivers. Signal conditioning circuits are designed to filter and amplify the signals to provide desired output. The main aim of this project paper is to develop a micro controller based system through which we can manage patient's health status remotely. The temperature sensor such as LM35 which will provide the analog output based on the temperature value. The LM35, ECG Electrodes and the Respiration sensor are used. The sensor values are fed to ARM9 processor. Using GSM modem the parameter values will be sent to the Doctor. The respiration rate is sensed using the pulse oximeter sensor. A portable, battery and Graphical LCD Display used to Plot the Graph depends on the ECG value and also display respiration rate and temperature Value. There are three electrodes is used to measure the ECG waves in which two electrode is fixed with left and right hand another one electrode is fixed in the right leg which acts as reference ground electrode.

II. PROPOSED HARDWARE SYSTEM

There is need to develop biomedical devices that need to prevent, detect and control health problems. In this

project we built a life-saving preliminary diagnostic system which also includes an emergency response mechanism. Being light, compact, mechanically robust and portable it can also offer post surgery for heart patients without affecting their mobility. The system incorporates automated trained intelligence and hence it is easy to use. It can also identify improper electrode contact. It has a dual power source option and can be powered from either USB or through a battery. Above all, our system is low cost, sustainable for all countries. . In our system, a wearable ECG recording prototype is developed to transmit ECG signals of users. Parameters like heart rate along with pulse oximetry and body temperature are sent as a text messages to medical advisory using GSM. Then emergency first aid video is proposed it is automatically played on ARM 9 using a graphical LCD display.

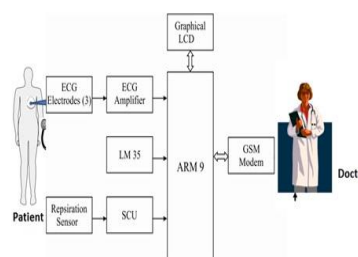

Fig.1: Block diagram of the proposed system

A. Sensing ECG Signals

The electrocardiogram does not assess the contractility of the heart. However, it can give a rough indication of increased or decreased contractility.

III IMPLEMENTATION

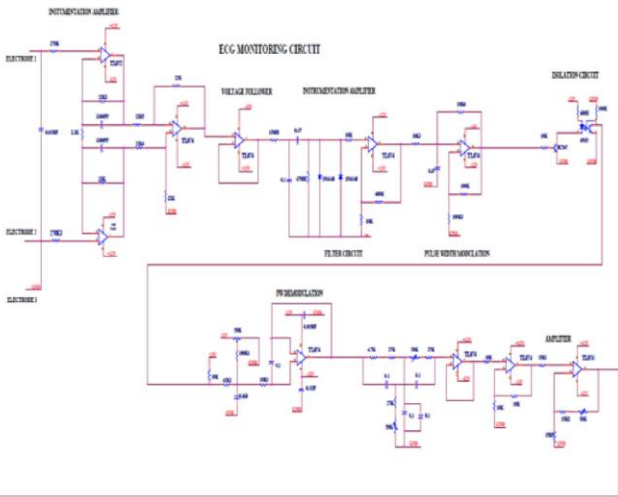

Fig.2: Block Diagram of the Proposed ECG Circuit
B. LM35 Sensor Module

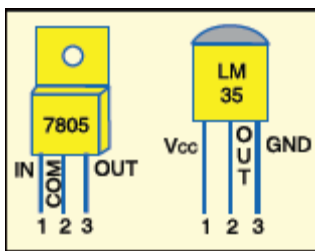

Fig.3: Block Diagram of the Proposed LM35 Sensor Module

C. Respiration Sensor Module

This circuit is designed to measure the respiration. In this circuit two thermostats is used for the respiration measurement which are connected in the resistor bridge network. The bridge terminals are connected with inverting and non inverting input terminals of the differential amplifier. The differential amplifier is constructed by the LM 741 operational amplifier. Here one thermistor is used for the respiration measurement. The differential amplifier provides the error voltage at its output. Then the error voltage is filtered by the next stage of the op-amp. The output voltage is converted to +12v to -12v square wave pulse through the comparator.

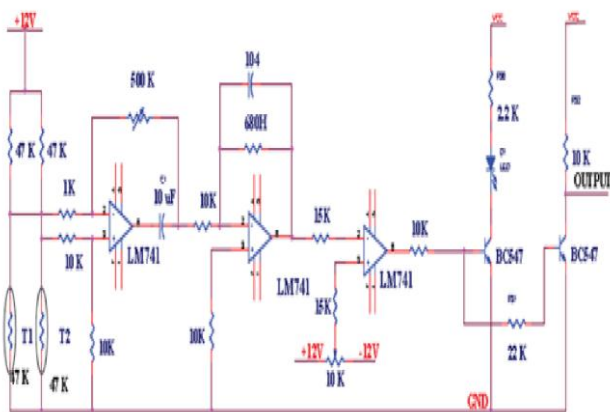

Fig.4: Block Diagram of the Proposed Respiration Circuit

Heart rate can be measured either by the ECG waveform or by sensing the pulse - the rhythmic expansion and contraction .The LM35 series are precision integrated-circuit Calibrated directly in ° Celsius (Centigrade) temperature sensors, with an output voltage linearly Linear + 10 mV/°C Scale Factor proportional to the Centigrade temperature. Thus the 0.5°C Ensured Accuracy (at +25°C) ° Kelvin, as the user is not • Rated for Full -55°C to +150°C Range the Suitable for Remote Applications output to obtain convenient Centigrade scaling.

A. ARM 9 Microcontroller features

Level/Edge mode on external interrupt source. Programmable polarity of edge and level. 60. Programmable duty cycle, frequency, and polarity dead-zone generation supports external clock sources.

IV. SOFTWARE USED

Windows Embedded CE 6.0 is the sixth major release of Microsoft Windows embedded operating system targeted like digital cameras. CE 6.0 features a kernel which supports 32,768 processes, 2 GB of virtual address space, up from 32 MB. The OS currently serves as the basis for the Zone 5.2. Windows Phone 7, the first major release of the Windows Phone.

V.RESULTS

The experimental results that we have built the prototype of a life saving Preliminary diagnostic system which also includes an emergency response mechanism. Being light, compact, mechanically robust and portable it can offer post surgery care for heart patients without affecting their mobility. It can detect unidentified signals, which may arise due to improper electrode contact. It has a dual power source option and can be powered from either USB or through a battery. Above all, our system is low cost and is suitable for all.

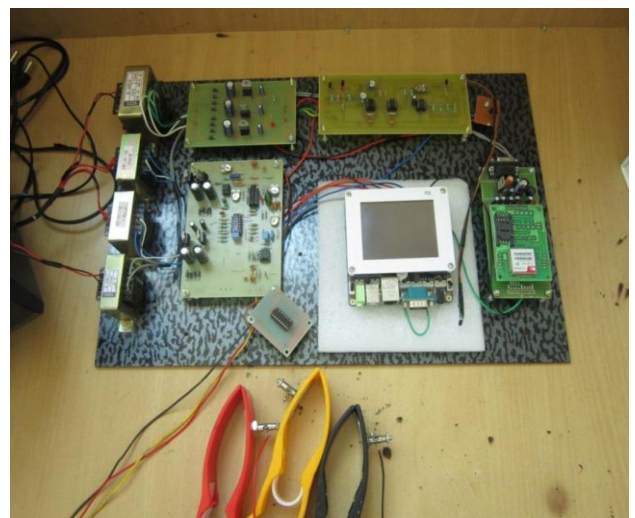

Fig.5: Block Diagram of the Proposed ECG Circuit

VI. CONCLUSION

Parameters like heart rate along with pulse oximetry and body temperature are sent as a text messages to medical advisory using GSM. Then emergency first aid video is proposed it is automatically played on ARM 9. The device alarms when the heart beat & the body temperature & Respiration exceed the provided threshold value.

VII. FUTURE WORK

This includes the improvement of the overall device performance and rigorous on-field testing of the device. Other extensions include that the patients can wear like coat and can be implemented in other signal processing techniques can be developed and adding pulse oximetry, instrumentation and further development of telemedicine applications using this device.

REFERENCES

- [1] Mohamed O.Diab, Reem Abou Marak/Brome, Mustapha Dichari, and Bassam Moslem "The Smartphone Accessory Heart Rate Monitor", *2013 IEEE*, pp. 1-4, 2013.
- [2] Souvik Das "The Development of a Microcontroller Based Low-Cost Heart Rate Counter for Health Care Systems" *International Journal of Engineering Trends and Technology- Volume4, Issue2- 2012*, pp. 42-44.
- [3] Link: www.emo.org.tr/ekler/a568a2aa8c19a31_ek.pdf
- [4] Edwards S., "Heart rate Monitor Book", Leisure systems international, 1993.
- [5] Chen M, "The Infrequency of Resting Heart Rate to Cardiovascular Disease Prognosis," *Hainan Medical Journal*, 2007.
- [6] Wang et al., "Design Of Portable Heart Rate Acquisition Instrument Bases On Bluetooth Transmission", *7th International Conference on Wireless Communications, Networking and Mobile Computing (Wicom)*, IEEE journal, ISBN: 978-1-4244-6250 6, pp. 1-4, 2011.